

## Exhibiting conditions and terms

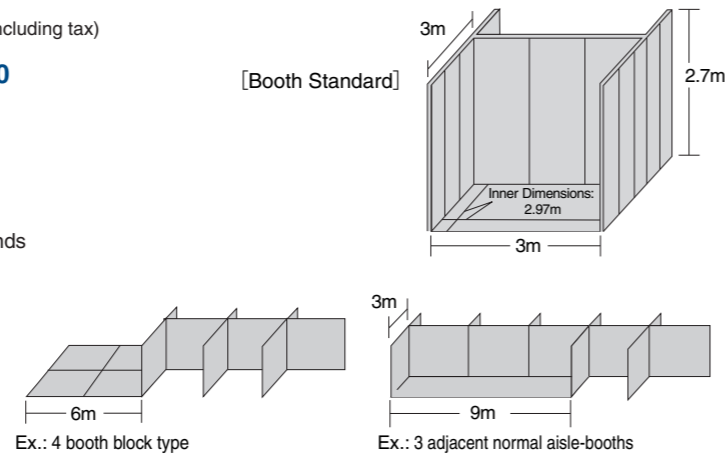

- **Booth specifications** Booth dimensions front width (open) : 3m × depth: 3m × height: 2.7m
- **Booth prices** 367,500yen per booth (including tax)
- **Application deadline** August 31 (Tue), 2010
- **Schedule**

August 31 (Tue), 2010	Deadline for Applications
end of September	Sending Floor Plan
middle of October	Website for visitors open
November 22 (Mon) ~ 23 (Tue)	Move - In, Setting up Stands
November 24 (Wed) ~ 26 (Fri)	"Exhibition"
November 26 (Fri)	Move - Out



# JIMA 2010 Japan Inspection Instruments Manufacturers' Show

24th(Wed) – 26th(Fri) November 2010  
Tokyo Big Sight 10:00–17:00

### Concurrent exhibitions

- SENSOR EXPO JAPAN 2010
- INTERMEASURE 2010

[www.jima-show.jp](http://www.jima-show.jp)



*Inspection and Measuring ensure Safety and Quality*

### Guide for potential exhibitors

Organizer : JIMA (Japan Inspection Instruments Manufacturers' Association)  
Special cooperation : Fuji Sankei Business i.



## Access to venue

URL: <http://www.bigsight.jp/english>



### Tokyo Big Sight

3-11-1 Ariake, Koto-ku, Tokyo 135-0063, Japan  
Tel. +81-3-5530-1111 Fax. +81-3-5530-1222

- 5 min. walk from Rinkai Line "Kokusai Tenjijo" (International Exhibition Hall) station  
(5 min. ride from JR/Subway Shin-kiba station, ¥ 230)
- Tokyo Waterfront New Transit "Yurikamome" (monorail) "Kokusai Tenjijo Seimon" station (a 20 minute ride from JR/Subway "Shimbashi" station, ¥ 370)
- Route Bus (¥ 200)  
Higashi 16/Kai 01 (東 16 海 01) : a 10-minute ride from Toyosu station to Tokyo Big Sight  
Higashi 16 (東 16) : a 30-minute ride from Tokyo station, Yaesu-minami-guchi to Tokyo Big Sight  
Kai 01 (海 01) : a 30-minute ride from Monzen-Nakacho station to Tokyo Big Sight  
Niji 01 (虹 01) : a 30-minute ride from Hamamatsucho station to Tokyo Big Sight
- Shuttle boat ("water bus"): disembark at Ariake Kyakusen (Ariake Port) terminal  
(a 20 minute ride from Hinode Pier/Hinodesanbashi, ¥ 350)

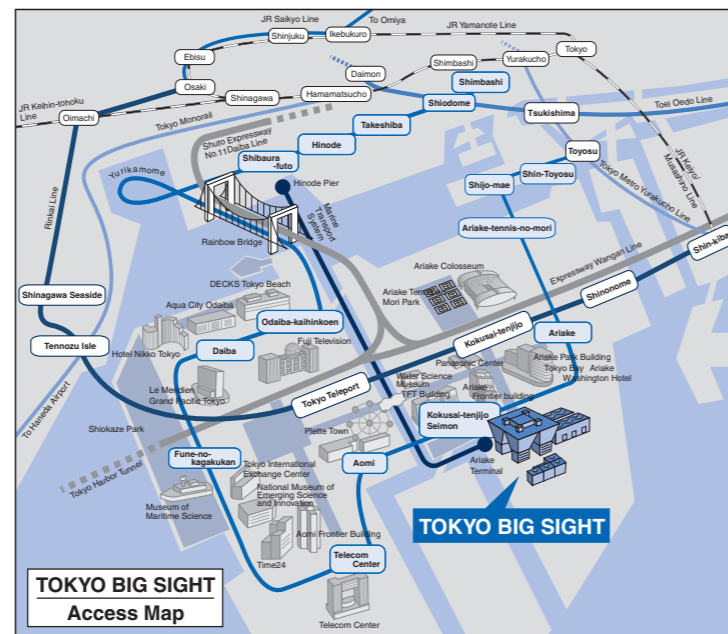

## Application and inquiry

<Organizer> **JIMA** General Incorporated Association  
Japan Inspection Instruments Manufacturers' Association

<Project Department> **Fuji Sankei Business i.**  
Nihonkogyo Shimbun Shinsha., Ltd. (Promotion Division) 1-7-2 Otemachi, Chiyodaku, Tokyo 100-8125 Japan  
TEL. +81-3-3273-6180 FAX. +81-3-3241-4999 URL: <http://www.business-i.jp> E-mail: [info@jima-show.jp](mailto:info@jima-show.jp)

# JIMA 2010 Inspection and Measuring ensure Safety and Quality

## Upcoming JIMA 2010



Japan Inspection Instruments Manufacturers' Association  
Chairman  
**Tsutomu Matsushima**

The Japan Inspection Instruments Manufacturers' Association is the only domestic group for manufacturers producing nondestructive inspection systems. For nondestructive inspection, we utilize ultrasonic, magnetic, eddy-current, X-ray, infrared light, and other technologies in various fields to protect human life and support the production of high quality products.

At our JIMA show, which is held every two years, we host a collection of the latest inspection and measuring technologies and introduce them to public through exhibitions, technology seminars, and other means in order to further the development of our industry. Additionally, as an important feature of this show, two exhibitions for measurement equipment, and sensors, related to this field will be held concurrently, providing rich business opportunities such as securing new contracts and expanding markets for exhibitors.

Member groups and committees are working together and preparing to host JIMA 2010. We would be grateful if you would support our efforts by exhibiting your products and attending the show.

## JIMA2010, Japan Inspection Instruments Manufacturers' Show

### Subject to exhibiting / exhibition

All the instrumentation and devices, etc regarding non-destructive inspection and measurement



#### ● Categorized by method

RT, UT, ET, MT, PT, SM, AE, VT, Laser, Infrared etc.

#### ● Categorized according to application usage

measurement/sizing (length, thickness, width), material evaluation (discrimination, electric conductivity, extraneous material, hardness, degree of hardening, poor weld, poor adhesion, elastic modulus measurement), dent (cracks, lamination, void, hollow), others (contamination detection, inclusion detection, publication, information etc.

### Visitor categories

All the manufacturing industries and safety maintenance engaged in inspection, measurement, testing and evaluation.



- Processing and/or manufacturing companies of Automobile, electronics, semiconductors, food, medical related products, heavy industries, industry, civil construction, aerospace instruments, vehicles, ships and vessels, tools and dies etc.
- Manufacturers of materials such as iron, refining, metal, non-metal, glass, plastic, ceramics etc. (in terms of material inspection)
- Power related entities: electric power generating, retailing, chemical/fuel/nuclear power plants
- Research Centers, Examination Facilities, Academic Institutions (Universities, Colleges) etc.

\* Due to the concurrent convening of multiple related shows, a spillover effect of visitors from these fields can be expected. (concurrently held with joint admission)

### Report on the previous show

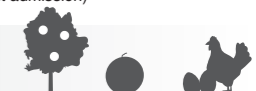

#### JIMA2009 Japan Inspection Instruments Manufacturers' Show

Wed.8th – Fri.10th April 2009 Tokyo Big Sight

concurrent: SENSOR EXPO JAPAN 2009, TEST2009, INTERNATIONAL CERAMIC EXHIBITION 2009

Size : 291 corporations / associations, 421 booths (4 events total)

[63 corporations / associations, 100 booths (JIMA 2009) ]

Number of visitors registered: 66,426 persons (4 events total)

#### ● Types of visitor

##### Percentage of visitors by industry

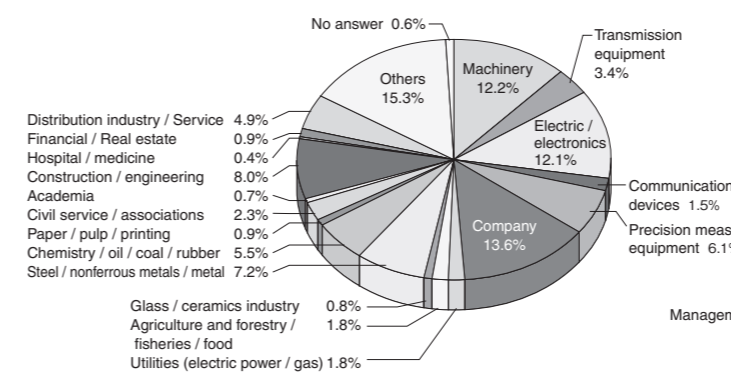

##### Percentage according to profession

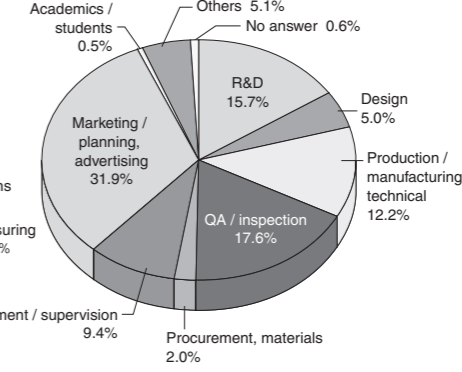

※This image is from the 2009 fair

## Outline of exhibition

**Exhibition name:** Japan Inspection Instruments Manufacturers' Show / JIMA 2010

**Date/Period:** Wed. 24th – Fri. 26th November 2010, 3 days 10:00-17:00

**Venue:** Tokyo Big Sight, East Hall [Ariake-Tokyo International Exhibition Center]

**Admission fee:** 1,500yen

● **Organizer:** General Incorporated Association Japan Inspection Instruments Manufacturers' Association

● **Special cooperation:** Fuji Sankei Business i.

● **Supported by:** Ministry of Economy, Trade and Industry

Ministry of Education, Culture, Sports, Science and Technology

Ministry of Land, Infrastructure, Transport and Tourism

(above: according to plan)

● **Concurrent exhibitions:** SENSOR EXPO JAPAN 2010

INTERMEASURE 2010

## Concurrent exhibitions (Common Entrance with JIMA)

### ● SENSOR EXPO JAPAN 2010

Japan's only exhibition covering all fields related to new sources of sensing technology

### ● INTERMEASURE 2010

International trade show related to measurement, test and control technology

## ● Comments from the previous show's participants

We compared and reviewed the newest inspection systems. We asked several companies for estimates of the cost of future adoption.

Quality assurance division chief, attendee

We were able to find technologies that could be applied to a new product. We will plan on visiting the research institution soon.

Manufacturer board member, attendee

We received more inquiries than we had expected. Many users were looking for solutions and we were able to pitch our proposals and discuss business matters with them.

Sales division chief, exhibitor

As attendees from concurrent shows were able to attend freely, we had many of them visit our section. We received contacts and inquiries from attending businesses we previously had no contact with.

CEO, exhibitor